

## LICENSING SUB-COMMITTEE

Date: Friday 11 March 2016  
Time: 10.00 am  
Venue: Bad Homburg Room, Civic Centre, Paris Street, Exeter

Members are invited to attend the above meeting to consider the items of business.

If you have an enquiry regarding any items on this agenda, please contact Howard Bassett, Democratic Services Officer (Committees) on 01392 265107 or email [howard.bassett@exeter.gov.uk](mailto:howard.bassett@exeter.gov.uk)

Entry to the Civic Centre can be gained through the Customer Services Centre, Paris Street.

*Membership -*  
Councillors Choules, Henson and Sheldon

### Agenda

#### **Part I: Items suggested for discussion with the press and public present**

##### **1 Appointment of Chair**

To appoint a Chair for the meeting.

##### **2 Declarations of Interest**

Councillors are reminded of the need to declare any disclosable pecuniary interests that relate to business on the agenda and which have not already been included in the register of interests, before any discussion takes place on the item. Unless the interest is sensitive, you must also disclose the nature of the interest. In accordance with the Council's Code of Conduct, you must then leave the room and must not participate in any further discussion of the item. Councillors requiring clarification should seek the advice of the Monitoring Officer prior to the day of the meeting.

##### **3 LOCAL GOVERNMENT (ACCESS TO INFORMATION) ACT 1985 EXCLUSION OF PRESS AND PUBLIC**

To pass the following resolution:

**RESOLVED** that, under Section 100A (4) of the Local Government Act 1972, the press excluded from the meeting for items 5 and 6 on the grounds that they involve the likely disclosure of exempt information as defined in paragraphs 1 and 2 of Part I of Schedule 12A of the Act.

**LOCAL GOVERNMENT (MISCELLANEOUS) PROVISIONS ACT 1976**

**4 Application for the renewal of a Private Hire Vehicle over 8 years old (Mr AG)**

To consider the report of the Assistant Director Environment.

(Pages 3 -  
28)

**Part II: Items suggested for discussion with the press and public excluded**

**LOCAL GOVERNMENT (MISCELLANEOUS PROVISIONS) ACT 1976 AND TOWN POLICE  
CLAUSES ACT 1847**

**5 Hearing for a Drivers' Licence**

To consider the report of the Assistant Director Environment.

(Pages 29  
- 42)

**6 Hearing for a Drivers' Licence**

To consider the report of the Assistant Director Environment.

(Pages 43  
- 50)

**Individual reports on this agenda can be produced in large print on request to Democratic Services (Committees) on 01392 265107.**

## REPORT TO LICENSING (SUB) COMMITTEE

**Time and Date of Hearing:** 10.00 11 MARCH 2016 PART 1 Matter

**Report of:** Environmental Health and Licensing Manager

**Type of Application:** Request for the GRANT of a Private Hire vehicle over 4 years

**Legislation:** Local Government (Miscellaneous Provisions) Act 1976

Town Police Clauses Act 1847

**Ward Application Refers to:**

Not Applicable

**Applicant:** Mr A H Goode

**Premises Address:** Not Applicable

### 1. What is the report about?

- 1.1 An application has been received from Mr A H GOODE for the RENEWAL of a private hire vehicle over 8 years old. This is a matter that cannot be dealt with under delegated powers.

### 2. Are there any representations?

- 2.1 There is no provision in the legislation for anyone to submit representations relating to this kind of application.

### 3. Report details:

- 3.1 The vehicle, a Fiat Ulysse registration mark PK04 ZJV was first registered on 14 April 2004 making the vehicle over 8 years old at subsequent licensing so cannot be dealt with under delegated powers.
- 3.2 The vehicle has been previously licensed with Exeter CITY Council since 5 February 2008 and the vehicle is currently 11 years and 10 months old. The vehicle has been presented to the Licensing Sub Committee on more than one previous occasion for an extension to the licence.
- 3.3 Attached to the report is the current MOT (dated within 3 months), the full inspection report and photographs.
- 3.4 The vehicle was checked by a Licensing Enforcement Officer on 1 March 2016 and was found to be in a satisfactory condition.

### 4. What are the legal aspects?

- 4.1 The Licensing Sub-Committee are required only to ensure that Public safety is not compromised by the granting of an extension of the licence. If they are satisfied that safety is reasonably assured they may grant the licence for a maximum of 12 months or such shorter period as they see as appropriate.

### 5. Recommendations:

- 5.1 The Licensing Sub-Committee are asked to determine the application having regard to current policy.

## **Environmental Health and Licensing Manager**

### **Local Government (Access to Information) Act 1972 (as amended)**

**Background papers used in compiling this report:-**

None

Contact for enquires:

Democratic Services (Committees)

Room 2.3

01392 265275

### **N.B THIS IS NOT PART OF THE REPORT**

#### **LOCAL GOVERNMENT (MISCELLANEOUS PROVISIONS) ACT 1976**

#### **HACKNEY CARRIAGE AND PRIVATE HIRE VEHICLE / DRIVERS LICENCES**

You are invited to appear before the Licensing Sub-Committee to speak in support of your application. A legal or other adviser may accompany you but may not appear instead of you.

### **Your Application**

Depending on the circumstances, your application may be heard in part two of the Committee meeting procedures from which members of the public and press are excluded. You will be notified in advance if your application will be a part two matter, if you have not been advised of this, the hearing will be in the Public domain.

You or your adviser would be expected to respond to an officer's verbal introduction outlining the above report. You or your adviser may be asked questions and may be invited to ask questions if appropriate.

At the end of the hearing you will be asked to withdraw and the Committee will reach a decision. On conclusion of the decision making process you will then be recalled and the decision announced.





# Norman Levenson

MIML, Eng. Tech., MSOE, MKITE, IMIARA, MPIRA



## Consultant Automotive Engineer & Assessor

### VEHICLE EXAMINATION REPORT

#### YOUR ATTENTION IS DRAWN TO THE TERMS AND CONDITIONS BELOW

The examination of the vehicle described in this report was of a purely external, visual nature and excludes any dismantling. No responsibility can be accepted for defects not visibly present at the time, or those not detected which fall outside the scope of the examination and (where possible) its limited road test. Road tests, when possible, are conducted for a limited duration and exclude high speed testing.

The accuracy of the instrumentation within the vehicle (speedometer, odometer, fuel and temperature gauges etc.), cannot be verified, neither can the future life expectancy of the clutch and brake linings, or the failure of mechanical components in the future. Statements on fuel and oil consumption levels will also be excluded.

It must be noted that, in the absence of a hoist or pit being available, the examination of the vehicle's underside would be unavoidably restricted.

<b>Report No.:</b> NL/29022016/4816	<b>Inspection Date:</b> 29 February 2016
<b>Customer Details</b> <b>Mr. A H Goode</b> <b>Sowton &amp; Topsham Cars</b> <b>Flat 2, Adelaide Court</b> <b>Exeter</b> <b>EX2 9EU</b>	<b>Inspection Address</b> <b>Flat 2</b> <b>Adelaide Court</b> <b>Exeter</b> <b>EX2 9EU</b>
<b>Telephone:</b> 07971 687112 or 01392 879090	<b>Telephone:</b>

#### VEHICLE DETAILS

<b>Make &amp; Model</b>	<b>Fiat Ulysse Prestigio JTD</b>	<b>Registration No.</b>	<b>PK04 ZJV</b>
<b>Colour</b>	<b>Blue Solid</b>	<b>Engine CC</b>	<b>1997 (approx)</b>
<b>Vehicle Identity Number. (VIN No.)</b>	<b>ZFA17900013136733</b>		<b>Confirmed YES</b>
<b>Engine No.:</b>	<b>Inaccessible on block      <b>NOTE: Engine Capacity cannot be confirmed</b></b>		
<b>V5 Registration doc checked</b>	<b>NO</b>	<b>MOT Certificate Expires</b>	<b>28/01/2017</b>
<b>Odometer Reading</b>	<b>385747 Miles</b>	<b>Service Records Seen</b>	<b>NO</b>

#### ENGINEER'S SUMMARY

#### PLEASE READ ALL THE PAGES OF THE REPORT

**SOME AREAS OUTLINED IN THIS REPORT AND HIGHLIGHTED FROM PAGE 5, REQUIRE FURTHER INVESTIGATION AND POSSIBLE RECTIFICATION. IT IS STRONGLY ADVISED THAT YOU DISCUSS THE FINDINGS OF THIS REPORT WITH THE VENDOR OR A REPAIRER PRIOR TO MAKING YOUR FINAL DECISION TO PURCHASE THE VEHICLE OR HAVE REMEDIAL REPAIRS CARRIED OUT. SOME DEFECTS MAY BE EXPENSIVE TO RECTIFY AND THIS MUST BE CONSIDERED PRIOR TO PURCHASE OR AUTHORISING REPAIRS.**

When considering this vehicle, its age and high recorded mileage must be taken into account. Due to the recorded mileage, the future life expectancy of components cannot be anticipated.

Generally, for its age and mileage, the vehicle was considered to be in a good and presentable condition, with one or two minor defects which may require attention in the future. It was evident that a considerable amount of work had been recently carried out on the vehicle (possibly to allow it to pass the recent MOT test).

The registration document and MOT certificate were not available at the time but from previous examination, the vehicle was first registered on 14/01/2004 and has had 4 keepers. An "on line" check confirmed the current MOT status.



**KEY:**  
**G** good for age  
**=** scratch  
**X** dent  
**C** corrosion  
**O** chip/rust  
**R** repair/paint

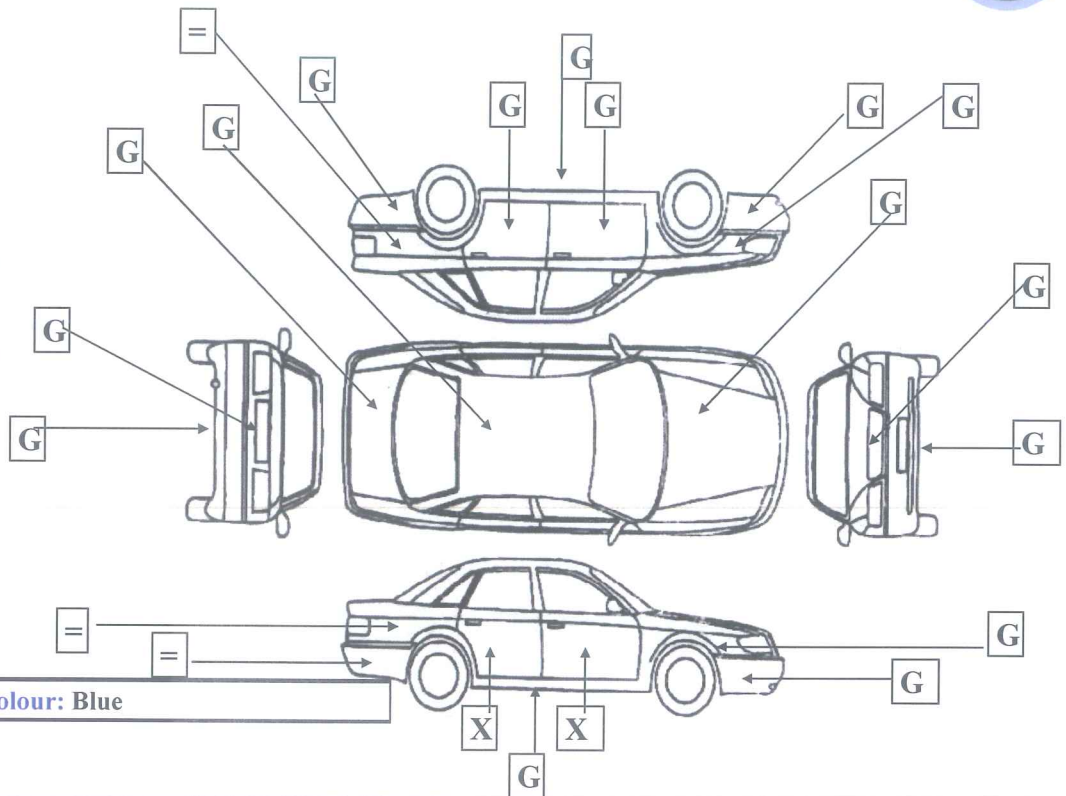

MPV 5/6 Seater : Colour: Blue

Minor marks or blemishes which are considered to be acceptable for the vehicle's age and type are not recorded and you should satisfy yourself in this regard.

**EVIDENCE OF BODYWORK REPAIRS**      **NO** None Visibly Noticed

**Comments**

The vehicle was presented in a clean condition throughout.

There were some minor marks, chips or light scratches etc., noted around the vehicle to a small degree. Some scratches were seen on the L/H/R wing area

Most of the interior trims were generally in a good condition, although the driver's seat was showing signs of wear, the driver's carpet was worn (this was covered by a loose carpet mat) through and there were some adjusting knobs missing from some seats.

**KEY FOR POINTS ON FOLLOWING PAGES**

<b>S</b>	<b>Satisfactory for age and recorded mileage</b>
<b>--</b>	<b>Could not be checked</b>
<b>X</b>	<b>Needs immediate attention</b>
<b>D</b>	<b>Desirable repair</b>
<b>N/A</b>	<b>Not applicable</b>
<b>Y</b>	<b>Yes</b>
<b>N</b>	<b>No</b>





### BODY EXTERIOR

1. Panel Condition/Alignment	S	5. Bumpers No plates – F/R	S	9. Body damage	No
2. Paintwork	S	6. Door locks – operation	S	10. Corrosion	No
3. Exterior trim	S	7. Fuel filler cover and cap	S	11. Mud flaps None Fitted	N/A
4. Glass	S	8. Soft top (operation/condition)	N/A	12.	

### ENGINE COMPARTMENT Diesel

13. Coolant Level/Condition	S	21. Clutch Fluid	S	29. Accelerator linkage	S
14. Coolant leaks	No	22. Brake Fluid	S	30. Body panels	S
15. Antifreeze	S	23. Engine Oil level	S	31. Bonnet catch	S
16. Radiator/Cap	S	24. External leaks (engine)	Yes	32. Bonnet hinges	S
17. Hoses/Pipes	S	25. Engine mountings	S	33. Cold starting	S
18. Drive Belts	S	26. Fuel Injection	S	34. Fast idle (cold)	S
19. Water Pump	--	27. Turbo	S	35. Noise level (cold)	S
20. Power Steering	S	28. Fuel pump/Pipes	S	36. Excess fumes/smoke	No

Spark plugs, Injectors or Glow Plugs are not removed.

It should be noted that a gas analyser has not been used to check exhaust emissions.

If no documentation is seen indicating camshaft drive belt replacement, to ensure future serviceability, it is important that the belt is replaced immediately and then at intervals specified by the manufacturer. It is in your best interests that you ensure that this is carried out.

### ELECTRICAL / CONTROLS

37. Starting system/Ignition lock	S	43. Stop lights	S	51. Horn	S
38. Battery charging system	S	44. Indicator/Hazard lights	S	52. Radio/Cass./CD/Aerial	S
39. Voltages at battery:	S	45. Reverse / Fog lights	S	53. Heater(s) / Fan controls	S
normal	S	46. Auxiliary lights	S	54. Air Con operation	S
charging	S	47. Interior / Panel lights	S	55. Door locking	S
40. Headlights	S	48. Screen dimsters Front + Rear	S	56. Windows Front + Rear	D
41. Sidelights /Running lights	S	49. Mirrors (electric)	S	57. Wipers/Washers Both F + R	D
42. Rear and No. plate lights	S	50. Controls/Instruments	S	58. Headlamp washers None	N/A

### INTERIOR / LUGGAGE COMPARTMENT

59. Steering Wheel/Adjustment	S	66. Door seals /hinges	S	73. Rear parcel shelf/blind	N/A
60. Seat upholstery – F/R	S	67. Interior sills	--	74. Boot/tailgate lock	S
61. Seat adjustment Elec. control.	S	68. Headlining/visors	S	75. Luggage area trim con	S
62. Seatbelts – F/R	S	69. Sun roof(s) Mech.	N/A	76. Illumination light	S
63. Carpets – F/R	S	70. Dash panel (condition)	S	77. Tool kit etc	S
64. Door trim panels	S	71. Cigarette lighter(s)	S	78. Soft top (material)	N/A
65. Door fitting /operation	S	72. Mirrors (internal)	S	79. Tonneau cover	N/A

### FRONT SUSPENSION / STEERING / UNDERFRAME

80. Engine underside leakage	Yes	85. Wheel hubs/bearings	S	90. Sub-frames/mountings	S
81. Steering joints/ball joints	S	86. Springs/suspension units	S	91. Suspension arms/mountings/joint	S
82. Steering Rack and Pinion	D	87. Sphers/Pipes/Hoses	N/A	92. Tie bars/anti roll bars	S
83. Chassis members	S	88. Dampers (condition / leaks)	S	93. Corrosion protection	Yes
84. Power steering Hydraulic	S	89. Power steering pipes/gaiters	S	94. Corrosion – floor/chassis	No

### REAR SUSPENSION / UNDERFRAME

95. Springs/suspension bars	S	99. Location rods/fixings	S	103. Sub-frames/mountings/axles	N/A
96. Anti roll bar	N/A	100. Bump stops/gaiters	S	104. Chassis members	S
97. Dampers/bushes	S	101. Wheel hubs/bearings	S	105. Corrosion protection	Yes
98. Suspension arms/fixings	S	102. Spheres/Pipes/Hoses	N/A	106. Corrosion – floor/chassis	No



<b>CLUTCH / TRANSMISSION Manual Gearbox</b>					
107. Fluid/Oil leaks	No	111. Casings/Axles/Differential(s)	S	115. Backlash	S
108. Cables/adjustments	S	112. Mountings	S	116. Gaiters	S
109. Hydraulic system	S	113. Drive shaft assembly	S	117. Propeller shaft(s)	N/A
110. Linkage (wear)	D	114. Universal/sliding joints	S	118. Prop.Bearings/Supports	N/A

<b>EXHAUST SYSTEM</b>					
119. Manifold(s)	S	121. Silencer(s)/Catalyst(s)	S	123. Joints/Couplings	S
120. Pipes	S	122. Heat shields/Mountings	S	124. System condition	Good

<b>FUEL SYTEM</b>					
125. Tank	S	127. Fuel lines	S	129. Evidence of leaks	No
126. Tank fixings	S	128. Breather pipes	--	130.	

<b>BRAKES</b>					
131. Master cylinder security	S	134. Flexible hoses	S	137. Hand/Parkbrake op/adjustment	S
132. Fluid leaks	No	135. Pipes/Connections	S	138. Hand/Parkbrake linkage	S
133. Servo/Power system	S	136. Discs/Pads/Drums Ltd wheels fitted	S	139. Pedal/Linkage	S

<b>WHEELS AND TYRES Type:Alloy Wheel Spare is full size Steel</b>					
140. Wheel Rims	S				
141. Wheel Trims	S				
Tyres	Make	Size	Type / Construction	Min tread depth	
142. RH Front	Mohawk M716	215/65 R15 96H	Radial/Tubeless	7 - 8mm	S
143. LH Front	Mohawk M716	215/65 R15 96H	Radial/Tubeless	7 - 8mm	S
144. RH Rear	Triangle CNNT GLS	215/65 R15 100H	Radial/Tubeless	5mm	S
145. LH Rear	Goldway G2001	215/65 R15 100H	Radial/Tubeless	2 - 3mm	D
146. Spare (Full Size Steel)	Firestone TZ300	215/65 R15 96H	Radial/Tubeless	1.6 - 2mm	D
147.					
148.					

<b>ROAD TEST</b>					
Finish Odom. Reading	385757 Miles	Conditions <b>Dry/Sunny Light Traffic</b>			
Test Duration	10 Miles	Speed achieved up to 60 M.P.H.			
149. Final drive op./Noise level	S	156. Instrument/Controls function	S	163. Road holding/Stability	S
150. Gearbox operation/noise level	S	157. Steering wheel alignment	S	164. General steering/Handling	S
151. Engine performance	S	158. Clutch operation	S	165. Footbrake operation	S
152. Engine noise	S	159. 4WD operation	N/A	166. Hand/Parkbrake operation	S
153. Excess smoke	No	160. Cooling fan operation	--	167. Suspension noise	No
154. Overheating evidence	No	161. Steering effort	S	168. Warning lights	S
155. Auto changes/Kickdown/Inhib.	N/A	162. Hot restarting	S	169.	
<b>FINAL CHECK</b>					
170. Oil leaks	Yes	171. Coolant leaks	No	172.	

**Please read all pages of this report**





## Essential & Desirable Repairs & Additional Comments

**It is strongly advised that the essential defects are investigated immediately or rectified prior to purchase of the vehicle and desirable repairs are carried out in the near future. Some defects may prove costly to rectify and this must be considered prior to purchase or authorising any remedial work.**

### Attention

Some vehicles are provided with a master key, which can be extremely costly to replace (sometimes in excess of £1000) as, in some cases, if the master key is missing the Engine Control Unit (ECU) may have to be replaced should you encounter problems. As well as this, some radios have codes to allow them to operate. Please satisfy yourself that you have all relevant keys and codes. You should also ensure you are given all relevant instruction manuals for the vehicle, radio, alarm and immobilisers as necessary

Item	Defect/Item requiring further investigation /rectification	D/X
24	Under the vehicle, the lower area of the engine oily and this requires investigation	D
56	The driver's door window switch was fitted the wrong way round in the consul	D
57	The wiper arms were worn and the L/H blade was held with a cable tie.	D
80	As 24 Above	D
82	There was very slight movement noted in the inner steering rack joints	D
110	There was a lot of movement/wear in the gear change which requires investigation	D
145	The L/H/R tyre tread depth was getting low	D
146	The spare tyre tread was close to its legal limit	D
NOTE	None of the above required immediate attention but should be considered and budgeted for the future.	
NOTE	The water pump, interior sills and fuel breather syste could not be checked during this examination.	
NOTE	Despite the engine being left to run before, during and after the road test, it did not reach a sufficient temperature to operate the radiator cooling fan.	

Reg. No.:  
PK04 ZJV

Ref. No.:  
NL/20022016/4816

*N. Levenson*

Date:  
29/02/2016





MOT Test Number

388928451215

Vehicle Registration Mark

PK04ZJV

Vehicle Identification Number

ZFA17900013136733

Make

FIAT

Model

ULYSSE

Colour

Blue

Issuer's Name

M. TAYLOR

Test Class

4

Country of Registration

Great Britain

Expiry Date

28 January 2017 (SEVENTEEN)

Issued

29 Jan 2016

Test Station

81422

Odometer Reading and History

29 1 2016: 385530 mi  
28 1 2015: 369596 mi  
29 1 2014: 347062 mi  
24 1 2013: 316961 mi

Inspection Authority

COUNTY TYRE SERVICE LTD  
ALPHINGTON STREET  
EXETER  
EX2 8LR 01392279292

Additional Information

To preserve the anniversary of the expiry date, the earliest you can present your vehicle for test is 29 December 2016.

Signature of Issuer



Advisory Information

About this document

- 1 This document is a receipt style certificate telling you that an MOT Test pass result has been recorded in the Driver & Vehicle Standards Agency's (DVSA's) database of MOT Test results; this can be verified at [www.gov.uk/check-mot-status](http://www.gov.uk/check-mot-status).
  - 2 A test certificate relates only to the condition of the components examined at the time of test. It does not confirm the vehicle will remain roadworthy throughout the validity period of the certificate.
  - 3 Check carefully that the details are correct.
  - 4 Whilst advisory items listed above do not constitute MOT failure items, they are drawn to your attention for advice.
  - 5 For further information about this document, please visit [www.gov.uk/getting-an-mot](http://www.gov.uk/getting-an-mot) or contact DVSA on 0300 123 9000\*.
- \*Your call may be monitored or recorded for lawful purposes.







**This page is intentionally left blank**



**This page is intentionally left blank**



**This page is intentionally left blank**





**This page is intentionally left blank**





**This page is intentionally left blank**



**This page is intentionally left blank**





**This page is intentionally left blank**



**This page is intentionally left blank**



# Agenda Item 5

By virtue of paragraph(s) 1, 2 of Part 1 of Schedule 12A  
of the Local Government Act 1972.

Document is Restricted

**This page is intentionally left blank**

By virtue of paragraph(s) 1, 2 of Part 1 of Schedule 12A  
of the Local Government Act 1972.

Document is Restricted

**This page is intentionally left blank**

By virtue of paragraph(s) 1, 2 of Part 1 of Schedule 12A  
of the Local Government Act 1972.

Document is Restricted

**This page is intentionally left blank**

By virtue of paragraph(s) 1, 2 of Part 1 of Schedule 12A  
of the Local Government Act 1972.

Document is Restricted

**This page is intentionally left blank**



By virtue of paragraph(s) 1, 2 of Part 1 of Schedule 12A  
of the Local Government Act 1972.

Document is Restricted

**This page is intentionally left blank**

By virtue of paragraph(s) 1, 2 of Part 1 of Schedule 12A  
of the Local Government Act 1972.

Document is Restricted

**This page is intentionally left blank**

By virtue of paragraph(s) 1, 2 of Part 1 of Schedule 12A  
of the Local Government Act 1972.

Document is Restricted

**This page is intentionally left blank**

By virtue of paragraph(s) 1, 2 of Part 1 of Schedule 12A  
of the Local Government Act 1972.

Document is Restricted

**This page is intentionally left blank**



By virtue of paragraph(s) 1, 2 of Part 1 of Schedule 12A  
of the Local Government Act 1972.

Document is Restricted

**This page is intentionally left blank**